

# R-LOCK STAINLESS STEEL

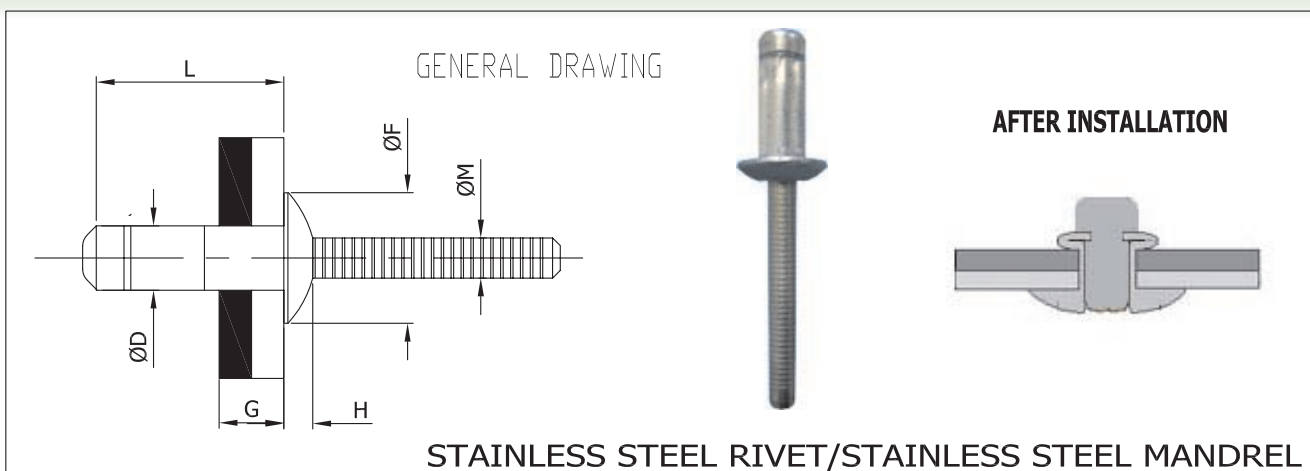

## DOME FLANGE

TYPE	Part Number	L mm	G mm	D mm	H mm	F mm	M mm	STRENGTH (Kgf)		Hole Size mm
								Shear	Tensile	
4.8 mm	SCCA62RL	9.0	1.5-3.5	4.8	2.2	9.8	3.02	600	440	5.0
	SCCA64RL	11.5	3.5-6.0							
	SCCA65RL	14.0	6.0-8.5							
6.5 mm	SCCA83RL	10.5	1.8-4.8	6.5	3.0	13.0	4.17	1480	850	6.6-6.8
	SCCA84RL	12.5	3.8-6.8							
	SCCA86RL	14.5	4.8-8.8							
	SCCA87RL	16.5	6.8-10.8							
	SCCA88RL	18.5	8.8-12.8							
	SCCA810RL	20.5	10.8-14.8							

## COUNTERSANK FLANGE

TYPE	Part Number	L mm	G mm	D mm	H mm	F mm	M mm	STRENGTH (Kgf)		Hole Size mm
								Shear	Tensile	
6.4 mm	SCCC85RL	13.5	4.8-7.8	6.4	2.0	10.0	4.17	1100 1300 1400	850	6.6-6.8
	SCCC86RL	15.5	6.8-9.8							6.6-6.7
	SCCC87RL	17.5	8.8-11.8							

## LARGE FLANGE

TYPE	Part Number	L mm	G mm	D mm	H mm	F mm	M mm	STRENGTH (Kgf)		Hole Size mm
								Shear	Tensile	
6.4 mm	SCCB83RL	10.5	1.8-4.8	6.4	3.1	16.3	4.17	1440	850	6.6-6.8
	SCCB84RL	12.5	3.8-6.8							
	SCCB86RL	14.5	4.8-8.8							
	SCCB87RL	16.5	6.8-10.8							
	SCCB88RL	18.5	8.8-12.8							6.5-6.7

Product specification are in effect at the time of publishing